



Nominal data

Type	RG 125-19/56	
Phase		1~
Nominal voltage	VAC	230
Frequency	Hz	50
Speed (rpm)	min ⁻¹	2550
Power consumption	W	20.0
Min. ambient temperature	°C	-30
Max. ambient temperature	°C	70
Air flow	m ³ /h	86
Sound power level	B	5.8

ml = Max. load · me = Max. efficiency · fa = Free air · cs = Customer specification · ce = Customer equipment
Subject to change

AC centrifugal compact fan

single-intake

Technical description

General description	Backward-curved impeller
Housing material	Scroll housing made of glass-fiber reinforced PBT plastic, housing base made of sheet steel
Weight	0.850 kg
Dimensions	180 x 180 x 40 mm
Impeller material	Glass-fiber reinforced PA plastic
Airflow direction	Radial: discharge through window in housing
Direction of rotation	Clockwise, viewed toward rotor
Storage	Ball bearing
Service life L10 at 40 °C	37500 h
Service life L10 at maximum temperature	20000 h
Cable	2 leads AWG 22
Motor protection	Protected from overload by impedance protection
Approval	VDE, CSA, UL, CE

Product drawing

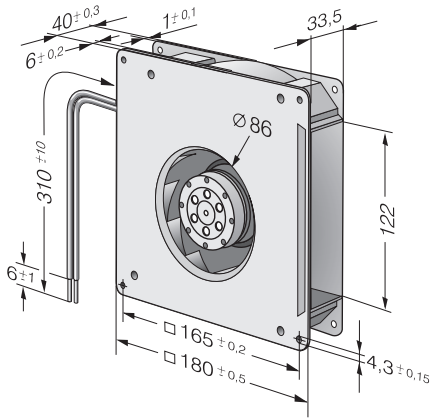

Curves: Air performance

